

SITE LOCUS
NOT TO SCALE

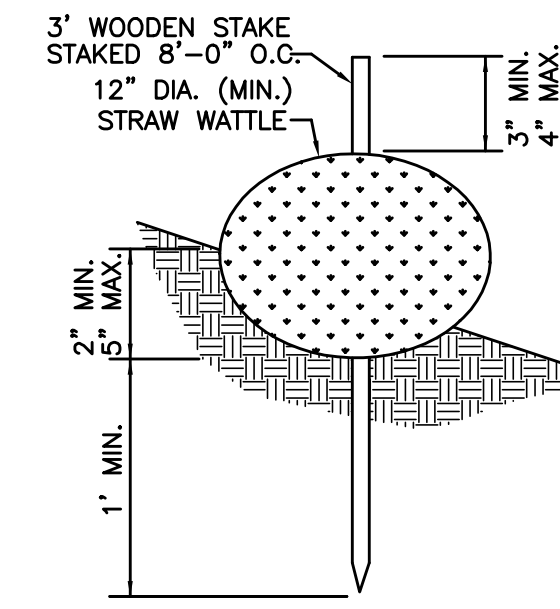

STRAW WATTLE DETAIL
NOT TO SCALE

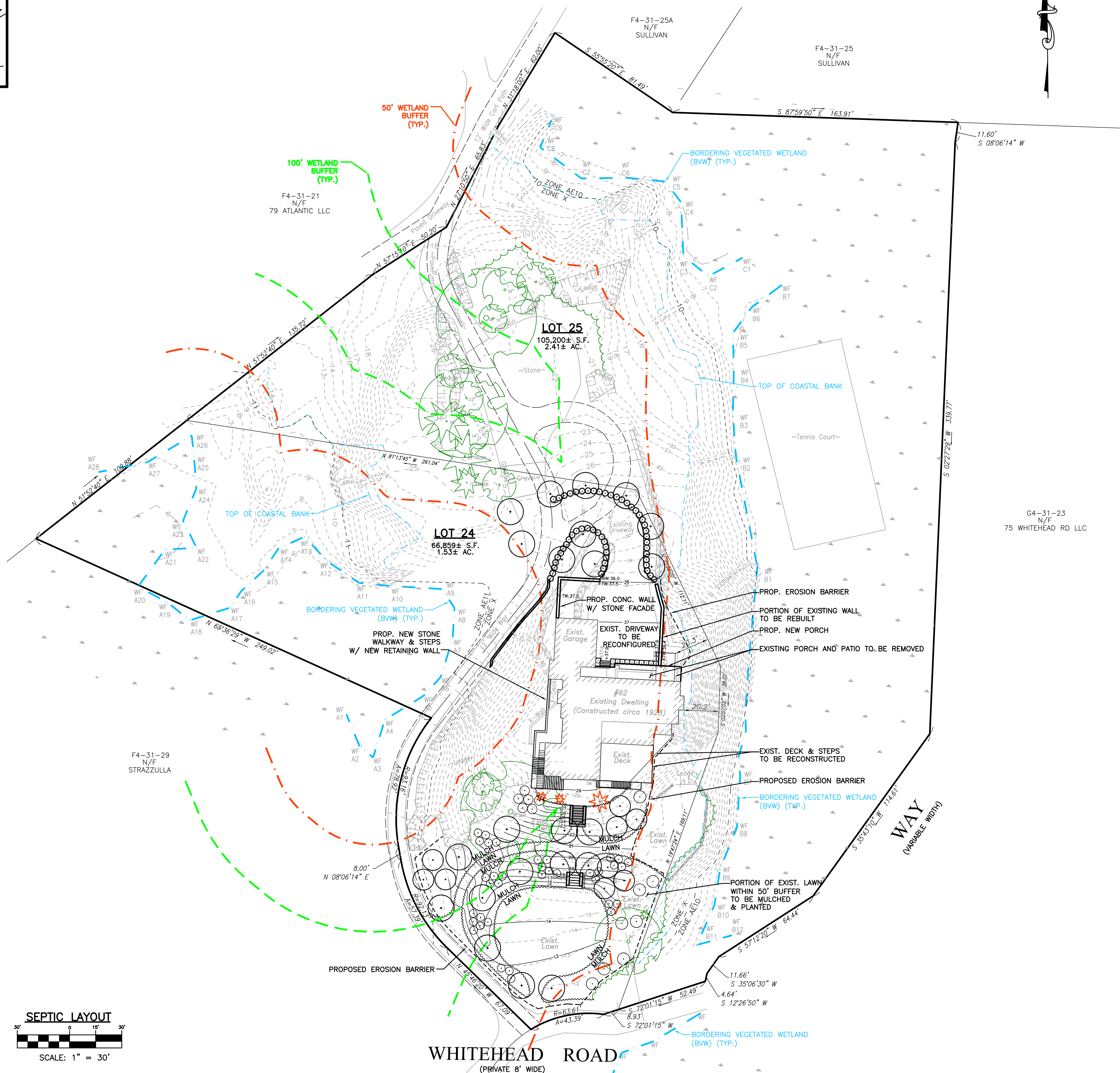

DEED REFERENCE:

NORFOLK COUNTY REGISTRY OF DEEDS
CERTIFICATE #200773
RECORD OWNER: BRIAN DOUGHERTY & NICHOLAS ROBERT

PLAN REFERENCE:

NO. 4760U, 4760W

ZONING REQUIREMENTS

TOWN OF COHASSET "RESIDENCE C" ZONING DISTRICT

CRITERIA	REQUIRED
LOT AREA	60,000 S.F.
FRONTAGE	50'
FRONT YARD	30'
SIDE YARD	20'
REAR YARD	30'
LOT WIDTH	150'
BUILDING COVERAGE*	20%
IMPERV. COVERAGE	30%

*BUILDING COVERAGE INCLUDES AREA OF IMPERVIOUS ROOFS.

GENERAL NOTES

- FLOOD ZONE NOTE: LOCUS IS LOCATED IN FLOOD ZONES X, AE (EL. 10), & AE (EL. 11) AS SHOWN ON F.I.R.M. MAP 25021C 0256E DATED JULY 17, 2012. ZONE AE IS DESIGNATED AS AN AREA OF 100 YEAR FLOODING WITH BASE FLOOD ELEVATIONS DETERMINED. ZONE X IS DESCRIBED AS AN AREA OF MINIMAL FLOODING ABOVE THE 100-YR FLOOD BOUNDARY.

TREE LEGEND

- EXISTING TREELINE
- EXISTING TREE TO BE REMAIN
- EXISTING TREE TO BE REMOVED (3) (4", 4" & 8")
- PROPOSED TREES (31)
- PROPOSED SHRUBS (103)

TREES TO BE NATIVE AND SELECTED FROM THE COHASSET CONSERVATION COMMISSION'S LIST OF APPROVED PLANTINGS. DECIDUOUS TREES TO BE 3-4" CALIPER. CONIFEROUS TREES TO BE 6-8' TALL AT TIME OF PLANTING.

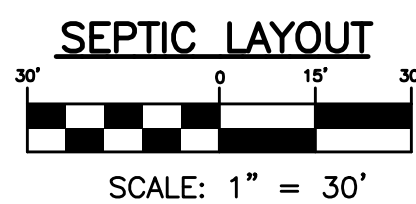

SCALE: 1" = 30'

	PREPARED BY:	
	PROJECT:	
APPLICANT:	BRIAN DOUGHERTY & NICK ROBERT 62 WHITEHEAD ROAD COHASSET, MA 02025	DRAFT: CKB CHECK: JMH JOB NO: 19-336 DATE: 12/15/2020 REV:
PLAN TITLE:	PLAN TO ACCOMPANY CONSERVATION NOI	SHEET: 1